

050-0150 Two Rotor Latch & Release Linkage



This two rotor latch is designed for medium to heavy-duty applications for off-highway entrance doors. It features an integrated linkage that allows for direct L-handle actuation and provides for ease of mounting and applications.

DESIGNED FOR:

- Door thicknesses of 1-7/8" or greater (47.6mm)
- Door weights of 50-200 lbs. (23-91 kg)
- Door seal pressures of 50-150 lbs. (23-68 kg) (suggested for best results)
- Use with TriMark 070-0200 Striker Bolt

Global Locations:

TriMark Corporation
500 Bailey Avenue
P.O. Box 350
New Hampton, Iowa 50659
United States
Tel: 641-394-3188
Fax: 641-394-2392
1-800-447-0343
www.trimarkcorp.com

TriMark Europe
Cedar Court
Walker road
Bardon Hill
Coalville LE67 1TU
United Kingdom
Tel: +44(0)1530 512460
Fax: +44(0)1530 512461
www.trimarkeu.com

TriMark (Xuzhou)
Building A5 Jingwu Road
Xuzhou Economic
Development Zone
Xuzhou, Jiangsu
221004 PR China
Tel: +86 516 8773 0018
Fax: +86 516 8773 0058
www.trimarkcn.com



TriMark. Interactive. Product. Selector



TriMark



TriMark Corporation

AVAILABLE:

- In left or right hand configurations (right hand shown)
- With drive bar receiver parallel to striker bolt or rotated in 15° increments (as illustrated)

INSTALLATION:

- (4) 1/4-20 UNC grade 5 mounting fasteners (not included).
- Tighten to the fastener manufacturers' recommended torque value, however, do not exceed 120 in-lbs (13 N-m)
- Maximum .312" (7.9mm) diameter mounting holes

LATCH & STRIKER INSTALLATION:

- Install striker bolt in door frame
- Close door carefully and check for interference between head of striker bolt and latch components
- Add or remove shims under striker bolt washer as required (outside diameter of shim should be larger than outside diameter of striker bolt washer)
- Adjust striker bolt vertically so door is not guided upward or downward while being closed
- CHECK TO DETERMINE THAT BOTH SECONDARY AND PRIMARY LATCHING POSITIONS ARE USABLE
- Door should be latched but not "closed" in secondary position and latched to anticipated "closed" position with respect to adjacent surfaces in primary position
- If both primary and secondary positions are not evident, readjust striker bolt
- After installation, check door alignment and door seal pressures

CAUTION: Product does not meet the locking requirements for FMVSS 206 (ECE R11).

Individual part dimensions are for reference only. Refer to individual part drawings for complete dimensions, specifications, and installation procedures. Engineering assistance and application drawings are available.

CAUTION: Applications of this latch may fall within the requirements of FMVSS 206 (ECE R11) and SAE J839 safety standards. These safety related requirements are dependent on door application, e.g. front and rear hinged doors, sliding doors, or hinged upward swinging doors. The entire door hardware system must be included in the design/analysis process: latch, handle, lock mechanism, rods/linkages, fasteners, hinges, etc. This ensures compatibility of all components within the hardware system. If FMVSS 206 (ECE R11) is a requirement, then all of the components within the door system must comply with strength, inertia and locking requirements as specified within the Standard. Note that this product complies with FMVSS 206 (ECE R11) when tested with approved TriMark Striker Bolts in accordance with SAE J839 and that this product meets FMVSS 206 (ECE R11) load requirements and may be used in FMVSS 206 (ECE R11) applications pending TriMark application approval.

For more information visit
www.trimarkcorp.com

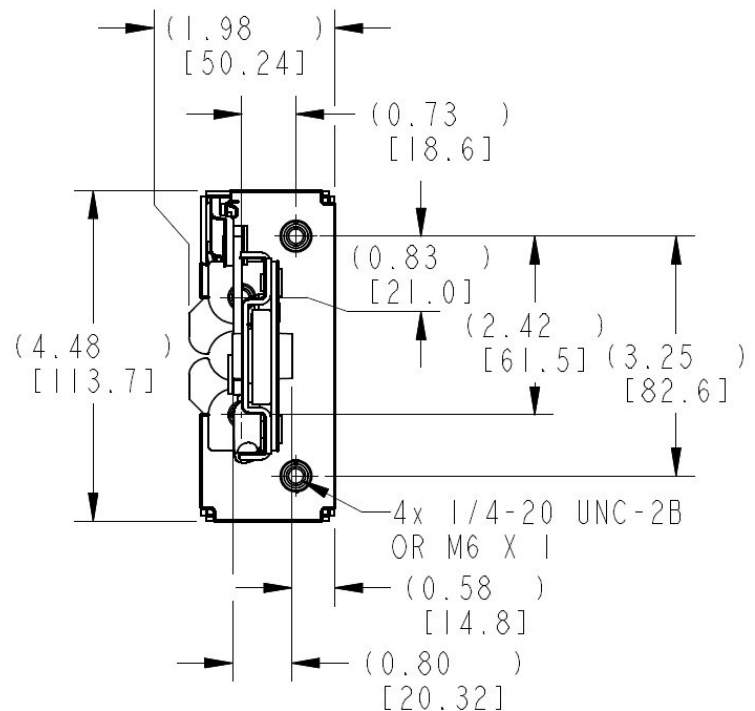
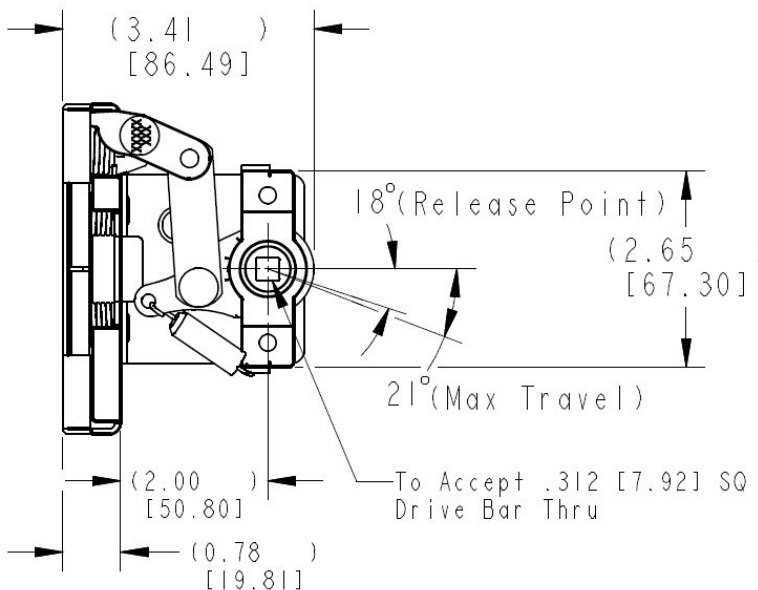

Optional Designs

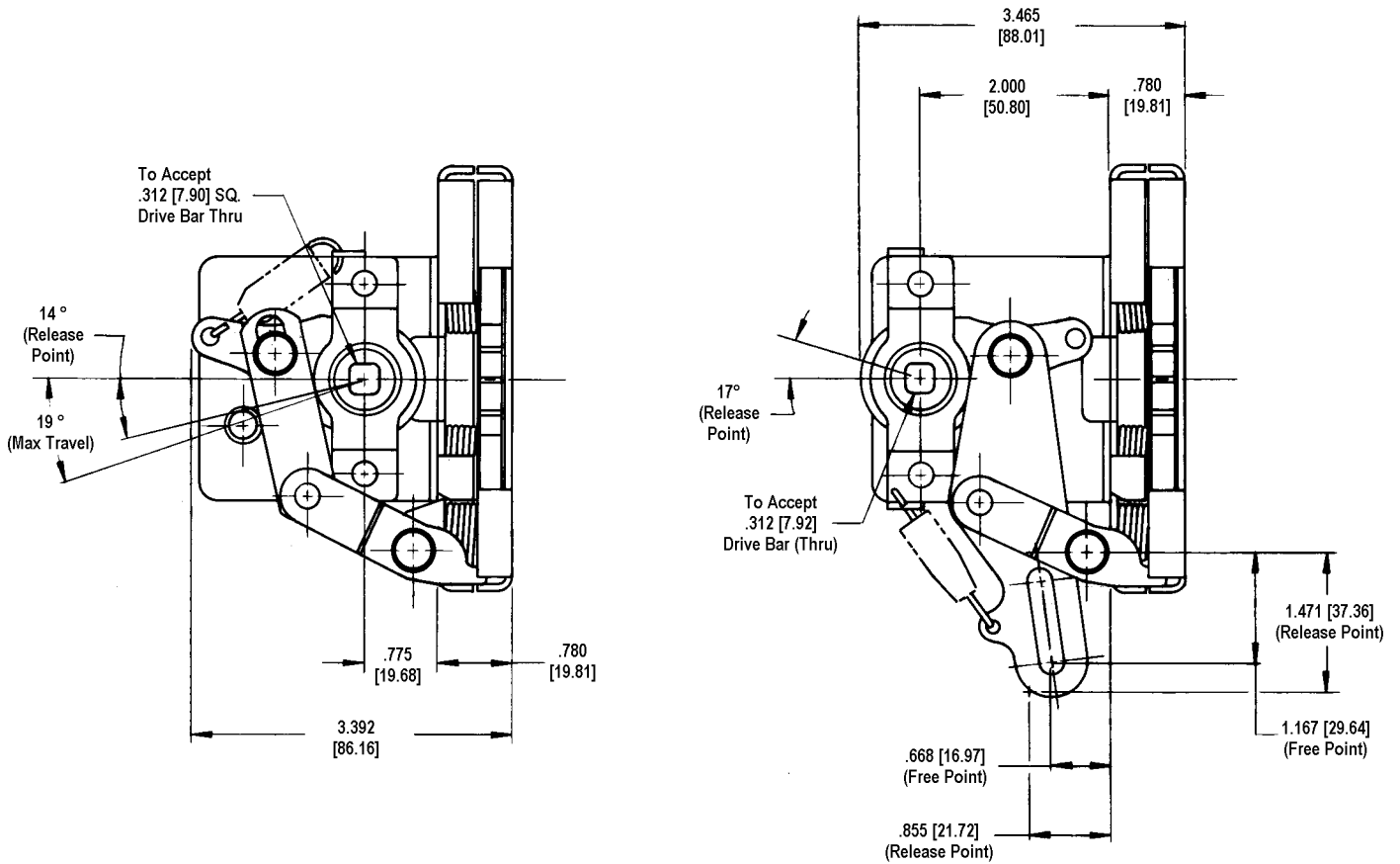

Door Conventions

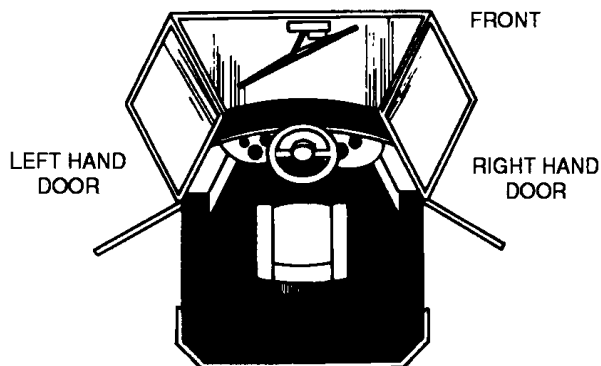

**AUTOMOTIVE STYLE
DOOR ARRANGEMENT**
REQUIRES: L.H. LATCH ON RIGHT HAND DOOR
R.H. LATCH ON LEFT HAND DOOR

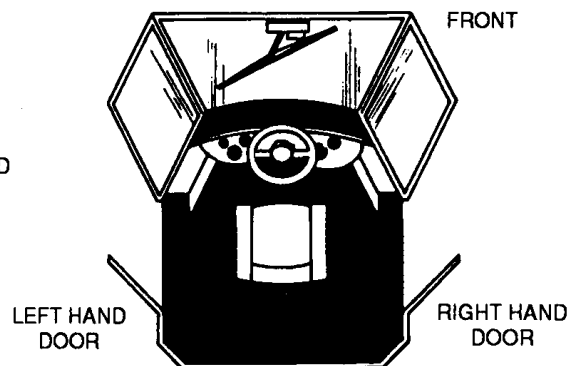

**CONVENTIONAL TRACTOR CAB
DOOR ARRANGEMENT**
REQUIRES: L.H. LATCH ON LEFT HAND DOOR
R.H. LATCH ON RIGHT HAND DOOR